

VLF test system

PHG 80 portable



The figure is illustrative.

Copyright © 2024
All rights reserved.

Reproduction, circulation in any form whatsoever, publishing on online services or the Internet, as well as duplication on data carriers, even in part or in an amended format, is allowed only with prior written permission of BAUR GmbH, 6832 Sulz, Austria.

We reserve the right in the interests of our customers to make amendments as a result of further technical development. Illustrations, descriptions and scope of supply are therefore not binding.

The names of products and companies are the trademarks or brand names of the relevant companies.

Table of contents

1	About this manual	6
1.1	Applicable documents	6
1.2	Structure of safety instructions	6
1.3	View settings	7
1.4	Note on the screenshots and graphics used	7
2	For your safety	8
2.1	Operation by qualified personnel	8
2.2	Intended use	8
2.3	Avoiding dangers, taking safety measures	9
2.3.1	Operation only in a technical secure state	9
2.3.2	No unauthorised modifications to the system	9
2.3.3	Checking and maintaining the safety devices and accessories	10
2.3.4	No operation during condensation	10
2.3.5	No operation in areas with risk of explosion and fire	10
2.3.6	Dangers when working with electric voltage	10
2.4	Special personal protective equipment	11
3	Product information	11
3.1	Full illustration	12
3.1.1	Front view	12
3.1.2	Ports on the back	13
3.2	PHG 80 VLF HV generator	13
3.3	SCU safety control unit	14
3.4	System connection cables	15
3.5	Rating plates	15
3.5.1	Rating plate of the system	15
3.5.2	Rating plate of the PHG VLF HV generator	16
3.6	Operating states	17
4	System checks to perform before commissioning	17
5	Connecting the system	18
5.1	Setting up the system	18
5.2	Establishing a de-energised state	18
5.3	Safety instructions	19
5.4	Connecting the system to the earthing	20

5.5	Connecting the system for cable testing.....	21
5.5.1	Cable with 3 screened phases.....	22
5.5.2	Cable with 1 screened phase.....	22
5.5.3	Unscreened cable with 3 phases.....	22
5.6	Connecting the system for cable sheath testing.....	23
5.7	Connecting the system for diagnostic measurements.....	24
5.8	Connecting the external emergency off unit.....	24
5.9	Connecting the system to the supply voltage.....	24
5.10	Securing the test area.....	24
6	Commissioning the system.....	25
7	Cable testing.....	26
7.1	About cable testing.....	26
7.2	Performing simplified cable testing.....	27
7.2.1	Inserting a test diagram into the report.....	28
7.2.2	Evaluating test results.....	28
7.3	Performing extended cable testing.....	29
8	Cable sheath testing.....	30
8.1	About cable sheath testing.....	30
8.2	Performing simplified cable sheath testing.....	31
8.2.1	Inserting a test diagram into the report.....	32
8.2.2	Evaluating test results.....	32
8.3	Performing extended cable sheath testing.....	33
9	Diagnostic measurements.....	34
10	Tips and tricks for the evaluation of measurements.....	34
11	Report preparation.....	35
11.1	Creating a report in the CABLE FAULT LOCATION software module.....	35
11.2	Creating a report in the TESTING AND DIAGNOSTICS software module.....	35
12	Decommissioning the system.....	36
12.1	Deactivating high voltage release.....	36
12.2	Taking the system and the test area out of operation.....	36
12.3	Exiting the measurement with the emergency off button during emergencies.....	37
13	Using the BAUR discharge and earth rod.....	39
14	Errors and corrective measures.....	40
15	Maintenance and care.....	41
15.1	Maintenance intervals.....	41
15.2	Cleaning the system.....	41

15.3	Checking and cleaning the connection cables and connection accessories.....	42
16	Transportation and storage.....	43
17	Warranty and After Sales	43
18	Disposal	44
19	Declaration of conformity	45
20	Index.....	46
21	Data sheet.....	48

1 ABOUT THIS MANUAL



1.1 Applicable documents

This user manual applies in conjunction with the following documents:

- User manual for the installed version of the BAUR Software 4
- User manual for the PD-TaD 62 or PD-TaD 80 portable PD diagnostics system
- Data sheet for the BAUR Software 4 for cable testing and diagnostics

1.2 Structure of safety instructions

The safety instructions in this user manual are presented as follows:

Danger symbol 	 SIGNAL WORD
	Type of danger and its source Possible consequences of violation. ▶ Measure to prevent the danger.

If a dangerous situation could arise at a specific step, the safety instruction is displayed immediately before this dangerous step and is shown as follows:



 **SIGNAL WORD**

Type of danger and its source. Possible consequences of violation.



1. Measure to prevent the danger.

Danger levels

Signal words in the safety instructions specify the danger levels.

 DANGER	Will lead to severe injuries or death.
 WARNING	May lead to severe injuries or death.
 CAUTION	May lead to light to moderate injuries.
NOTICE	May lead to material damage.

Danger symbols

	Warning about general danger
	Warning about electric voltage
	Warning about arcing faults

1.3 View settings

Symbol	Meaning
▶	You are requested to perform an action.
1. 2. ...	Perform the actions in this sequence.
a. b. ...	If an operation consists of several operating steps, specify these with "a, b, c". Perform the operating steps in this sequence.
1 2 ...	Numbering in the legend
▪	List
	Indicates further information on the topic.

1.4 Note on the screenshots and graphics used

The screenshots and graphics used are intended to illustrate the procedure and may differ from the actual state.

2 FOR YOUR SAFETY

We, the manufacturer, produce our devices and systems according to the latest technological standards and guarantee a high level of operational safety and reliability. However, responsibility for safe use lies with the responsible body¹ and operator². The responsible body and operator of the device or system are responsible for any injuries or damage resulting from non-compliance with this user manual.

This chapter *For your safety* in this user manual is intended to help you implement the required safety measures.

2.1 Operation by qualified personnel

The system may only be operated by qualified personnel. Qualified personnel are individuals who, thanks to their professional electrical engineering training, are able to identify and prevent dangers, and who are qualified to perform the respective tasks.

Before starting work, the responsible body and persons working with the system must have carefully read through and understood the user manual for the system, as well as the user manuals for all associated devices or systems.

2.2 Intended use

The PHG 80 portable VLF test system is used for cable and cable sheath testing of medium-voltage cables up to 50 kV.

The following diagnostic measurements are also possible in combination with the PD-TaD portable PD diagnostics system:

- Dissipation factor and partial discharge measurements
- Monitored Withstand Test with dissipation factor measurement (MWT with tan delta)
- Full Monitored Withstand Test (Full MWT)

If the system is not used in accordance with this stipulation, safe operation cannot be guaranteed. The manufacturer cannot be held liable for any damage to persons and property resulting from incorrect operation.

- ▶ To ensure safe use as intended, follow the instructions in this user manual.

¹ Responsible body is the person or group that is responsible for the safe operation of the device and its maintenance (EN 61010-1, 3.5.12).

² Operator is the person who uses the device for its intended purpose (according to the definition of user in compliance with EN 61010-1, 3.5.11).

2.3 Avoiding dangers, taking safety measures

- ▶ When erecting the test installations and operating PHG 80 portable, adhere to the latest applicable version of the following regulations and guidelines:
 - Accident prevention and environmental protection regulations applicable for your country
 - Safety instructions and regulations of the country where PHG 80 portable is being used
 - EU/CENELEC countries: EN 50191 *Erection and operation of electrical test equipment*
Other countries: The standard for erection and operation of electrical test equipment applicable for your country
 - EU/CENELEC countries: EN 50110 *Operation of electrical installations*
Other countries: The standards for operating electrical installations applicable in your country
 - Any other relevant national and international standards and guidelines
 - Local safety and accident prevention regulations
 - Employers' liability insurance association regulations (if any)

2.3.1 Operation only in a technical secure state

Safety, function and availability depend on the proper condition of the system.

- ▶ Operate the system and the integrated devices only in a technical perfect condition.
- ▶ In case of damage and malfunction, immediately stop the system, mark it accordingly and have the faults rectified by appropriately qualified and authorised personnel.
- ▶ Comply with the inspection and maintenance conditions.
- ▶ Use only accessories and original spare parts recommended by BAUR. The use of spare parts, accessories and special facilities that are not tested and approved by BAUR could adversely affect the safety, function and characteristics of the product.

2.3.2 No unauthorised modifications to the system

Accessories and spare parts

Upgrades, modifications or alterations to the system are strictly prohibited.

- ▶ Use only accessories and original spare parts recommended by BAUR. The use of spare parts, accessories and special fittings that are not tested and approved by BAUR could adversely affect the safety, function and characteristics of the system.

System configuration

The system you receive from BAUR is preconfigured and ready for operation.

Changes to the system configuration may be carried out only after approval from and if necessary, under the instruction of BAUR After Sales. Arbitrary changes to the system configuration can adversely affect the safety, functions and features of the system. Faults and problems that were caused due to unauthorised changes to the system configuration are not covered by the warranty.

Reinstallation of the BAUR Software

The BAUR Software is preconfigured by the manufacturer according to your system. If the BAUR Software is not reinstalled properly, configuration data could be lost, and faults could occur. In this case, there is no guarantee that the system will function without problems.

- ▶ Contact BAUR After Sales Service to check if it is actually necessary to reinstall the BAUR Software and if so, arrange for this to be done properly.

Faults due to improper reinstallation of the BAUR Software are not covered by the warranty.

External software

You may only install software that is required for carrying out measurement tasks and that has been explicitly approved by the authorised person in the company. Only the system administrator is permitted to carry out all software installations.

You are not permitted to install any additional programs without prior approval. This particularly applies for downloaded programs such as computer games, utilities, plug-ins for browsers, etc.

Faults and any changes in system settings due to installed external software are not covered by the warranty.

2.3.3 Checking and maintaining the safety devices and accessories

The safety devices and accessories must be inspected regularly for proper condition and function. The system must not be operated in the case of defects or non-functional safety devices.

The safety devices and accessories must not be changed, bridged or switched off.

2.3.4 No operation during condensation

Condensation can form in devices and systems due to temperature fluctuations and high air humidity, which in some components can result in leakage currents, flashovers and short-circuits.

- ▶ Always prevent condensation in devices. Temper the device and system before and during the measurements so that no condensation occurs.

2.3.5 No operation in areas with risk of explosion and fire



Measurements in direct contact with water, in environments with explosive gases and in areas with fire risks are not permitted. Possible danger areas include e.g. chemical factories, refineries, paint factories, paint shops, cleaning plants, mills and stores of milled products, tank and loading plants for combustible gases, liquids and solid matter.

2.3.6 Dangers when working with electric voltage

Personnel need to pay special attention and must be very careful while working with electric voltage.

Before starting work: Observe 5 safety rules

1. Disconnect the test object from all phases.
2. Secure the test object against reconnection.
3. Ensure that there is no voltage.
4. Earth all phases of the test object and short-circuit them.
5. Cover or cordon off adjacent live parts to prevent accidental contact and flashovers.

	 DANGER
	<p>Electric voltage</p> <p>Danger to life or risk of injury due to electric shock; risk of burns or electro-ophthalmia due to arcing faults.</p> <ul style="list-style-type: none"> ▶ Before commencing work, the operator must assess the risks for the specific working conditions. Protective measures are based on the risk assessment and must be followed at the workplace. ▶ Connect the system as described in this user manual. <p>The test object may still be live and carry dangerous voltage after the high voltage release has been deactivated.</p> <ul style="list-style-type: none"> ▶ Before removing the safety precautions, discharge, earth and short circuit all live parts.

2.4 Special personal protective equipment

Personal protective equipment based on the risk assessment for the relevant working conditions is part of the PHG 80 portable safety concept.

- ▶ Observe the internal operating instructions and the safety instructions applicable in your country.

3 PRODUCT INFORMATION

The PHG 80 portable VLF test system is used for cable and cable sheath testing of medium-voltage cables up to 50 kV.

The following diagnostic measurements are also possible in combination with the PD-TaD portable PD diagnostics system:

- Dissipation factor and partial discharge measurements
- Monitored Withstand Test with dissipation factor measurement (MWT with tan delta)
- Full Monitored Withstand Test (Full MWT)



Information on the following subjects is given in the chapter *Data sheet* (on page 48):

- Technical data
- Available methods
- Standard delivery
- Accessories and options

3.1 Full illustration

3.1.1 Front view



No.	Element	Function
1	PHG VLF HV generator	<p>Is used to generate:</p> <ul style="list-style-type: none"> ▪ VLF truesinus® voltage ▪ VLF square wave voltage ▪ DC voltage <p>Further information: Chapter <i>PHG 80 VLF HV generator</i> (on page 13)</p>
2	Discharge and earth rod	Is used to discharge and earth the test object
3	SCU safety control unit	<p>Is used to switch on the system and to release the high voltage and deactivate the high voltage release</p> <p>Further information: Chapter <i>SCU safety control unit</i> (on page 14)</p>
4	Laptop	Is used to control and set measurements as well as record and evaluate measurement data via the BAUR Software
5	Connection cables	<p>Are used to connect the system to the test object and to perform measurements</p> <p>Further information: Chapter <i>System connection cables</i> (on page 15)</p>

3.1.2 Ports on the back

All ports on the back of the system are described below. The number of ports depends on the system configuration.

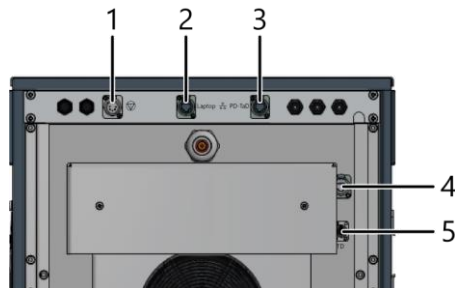

No.	Element	Function
1	 port	Is used to connect an optional external emergency off unit If no external emergency off unit is being used, this port is bridged with a jumper plug.
2	Laptop port	Is used to connect the laptop
3	PD-TaD port	Is used to connect the PoE cable for dissipation factor and PD measurement with the PD-TaD (option)
4	Network port	The network port is connected by the manufacturer. So as not to impair the system's function, do not alter the port.
5	TD port	Is used to connect the TD cable for dissipation factor measurement with the PD-TaD (option)

3.2 PHG 80 VLF HV generator

The VLF HV generator is used to generate voltages for cable and cable sheath testing:

- VLF truesinus® and VLF square wave voltage
BAUR VLF truesinus® digital technology offers load-independent voltage generation with digital control. The voltage is exact, symmetrical, and continuous.
- Stabilised DC voltage with positive and negative polarity



The VLF HV generator is controlled centrally via the BAUR Software.

3.3 SCU safety control unit

The SCU safety control unit is used:

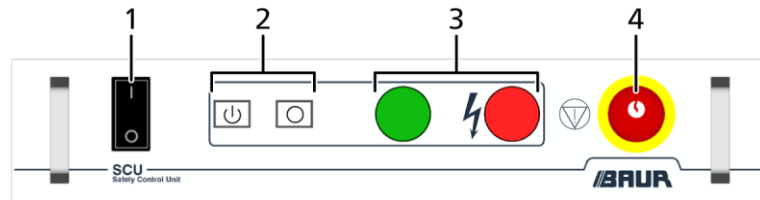
- to switch the system on and off
- to protect against unauthorised or unintentional restarting of the system
- to switch off the system in an emergency using the emergency off button
- to release the high voltage and to deactivate the high voltage release



No.	Element	Function
1	On/Off switch	Is used to switch the system on and off
2	 key	Changes the system to <i>Ready to switch on</i> operating state
	 key	Deactivates the high voltage release and puts the system into the <i>Ready for operation</i> operating state
3	Indicator lights	Indicate the system operating state: <ul style="list-style-type: none"> ▪ Green: <i>Ready for operation</i> ▪ Red: <i>Ready to switch on, In operation</i>
4	Emergency off button	Moves the system to the <i>Ready for operation</i> operating state. The emergency off button is equipped with a key lock to protect against restart, unauthorised start-up, and unauthorised or unintentional operation.

3.4 System connection cables

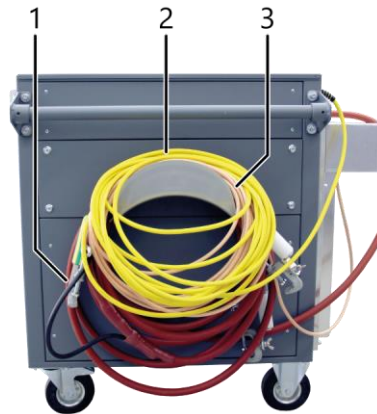

No.	Cable	Function	Minimum bend radius
1	HV connection cable	Is used to connect the system to the test object	90 mm
2	Mains supply cord	Is used to connect the system to the mains voltage	59 mm
3	Protective earthing cable	Is used to connect the system to the protective earthing	101 mm

3.5 Rating plates

3.5.1 Rating plate of the system



Element	Description
BAUR System	Indicates that it is a system with multiple components
XX XXX XX XXX	Serial number of the system
BAUR GmbH Raiffeisenstrasse 8; 6832 Sulz / Austria Tel.: +43 / 55 22 / 49 41-0 FAX: +43 / 55 22 / 49 41-3 www.baur.eu; e-mail: headoffice@baur.eu	Name and address of the manufacturer

3.5.2 Rating plate of the PHG VLF HV generator

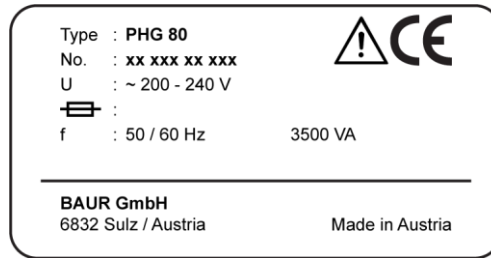

Element	Description
Type	Device designation
No.	Serial number
U	Supply voltage If several supply voltages are possible, these are given consecutively one after another.
☐	Not applicable here
f	Mains frequency
VA	Max. recorded apparent output
⚠	General warning sign Indicates that there is a potential risk of danger when using the product and hence the user manual must be observed
CE	CE mark Indicates that the device or system conforms to CE.
BAUR GmbH 6832 Sulz / Austria	Name and address of the manufacturer
Made in Austria	Indicates the country in which the device was manufactured.

3.6 Operating states

Out of operation

- All safety measures necessary before stepping into the test area have been met.
- All power supplies, signal and control electric circuits are switched off.

Ready for operation

- The safety measures of the *Out of operation* operating state that are necessary before stepping into the danger area are still in place.
- The power supplies for the signal and control current circuits of the switching devices are switched on.
- The test voltage supply is switched off and secured against accidental start.
- The system's green indicator light lights up.

Ready to switch on

- All accesses to the test area are closed. The safety measures of the *Out of operation* operating state that are necessary before stepping into the danger area are lifted.
- The test voltage supply is switched off.
- The system's red indicator light lights up.

In operation

- All accesses to the test area are closed.
- One or more test voltage supplies are switched on.
- The system's red indicator light lights up.

4 SYSTEM CHECKS TO PERFORM BEFORE COMMISSIONING

1. Operate the system only in a technical perfect condition.
2. Check the system and mechanical connections for damage.
3. Check other devices for damage that are not integrated in the system and that you intend to use.
4. Check electrical connections and connection cables for damage.
Use only undamaged connection cables.
5. Regularly check that the safety devices and accessories are in good condition and working properly.
This particularly applies for signal systems, emergency off units, earthing and short-circuit devices and ports.

5 CONNECTING THE SYSTEM

- ▶ Observe the safety instructions in chapter *For your safety* (on page 8).

5.1 Setting up the system



- ▶ Comply with the applicable accident prevention regulations and local conditions.
- ▶ Select the installation location for the system in such a way that
 - a stable position is ensured,
 - the system is easy to access for connection and operation purposes,
 - sufficient safety distances are maintained. You must comply with EN 50110 for the operation of electrical installations and EN 50191 for the erection and operation of electrical test equipment (EU/CENELEC countries) or the relevant standards applicable in your country.



5.2 Establishing a de-energised state

The following steps relate to the connection point and the far end:

1. Disconnect the test object from all phases.
2. Secure the test object against reconnection.
3. Ensure that there is no voltage.
4. Earth all phases of the test object and short-circuit them.
5. Cover or cordon off adjacent live parts to prevent accidental contact and flashovers.
6. Cordon off all metal parts or insulate with insulating safety plates.
7. Make sure that all metal parts are earthed.

5.3 Safety instructions

	 DANGER
	<p>Danger due to electric voltage, flashovers at the connection point, or arcing fault on connection</p> <p>Electric shock on touching live and active parts and due to residual charges and induction voltages;</p> <p>Burns, electro-ophthalmia, and hearing damage.</p> <ul style="list-style-type: none">▶ Use suitable personal protective equipment against electric shocks and arcing faults.▶ Observe the isolating distances.▶ Make sure that the workplace is de-energised. <p>Further information: Chapter <i>Establishing a de-energised state</i> (on page 18)</p> <ul style="list-style-type: none">▶ You may touch the parts that were under voltage only if they are visibly earthed and short-circuited.

	 DANGER
	<p>High electric voltage through potential increase</p> <p>A fault can cause flashovers in the device. In this case, a potential increase of the housing is possible due to high short-circuit currents.</p> <p>Danger due to the potential increase is reduced when a protective earthing is connected properly.</p> <ul style="list-style-type: none">▶ Connect the protective earthing carefully. The protective earthing cable should be as short as possible and of low impedance.

5.4 Connecting the system to the earthing

The illustration shows an example of a connection diagram with a 1-phase test object. Connecting the system to a 3-phase system is similar.

Required equipment

Suitable discharge and earth rod (included in the standard delivery)

- ▶ Observe the max. test voltage of the system. Further information: Chapter *Data sheet* (on page 48)

Procedure

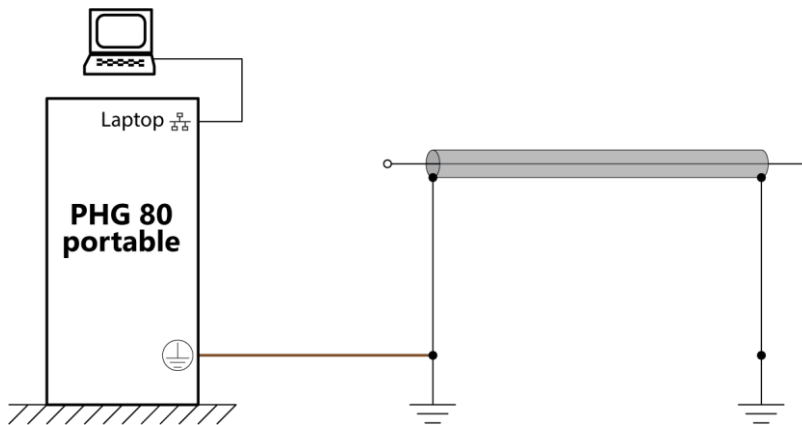

1. Make sure that the connection point and the far end are prepared for the measurement tasks.
Further information: Chapter *Establishing a de-energised state* (on page 18)
2. Connect the protective earthing cable of the discharge and earth rod to the station earth.
3. Unwind the system's protective earthing cable fully so that there are no loops.
4. Connect the protective earthing cable to the station earth - as close as possible to the station earth connection.

5.5 Connecting the system for cable testing

Connection diagram

- Cable with 3 screened phases (on page 22)
- Cable with 1 screened phase (on page 22)
- Unscreened cable with 3 phases (on page 22)

Procedure

1. Make sure that the connection point and the far end are prepared for the measurement tasks.
Further information: Chapter *Establishing a de-energised state* (on page 18)
2. Earth the system.
Further information: Chapter *Connecting the system to the earthing* (on page 20)
3. Unwind the HV connection cable fully.
4. The HV connection cable screen is used for the operational earthing. Connect the screen of the HV connection cable to the station earth. Select the location for connecting the screen to the station earth as follows:
 - as close as possible to the location where the test object screens are connected to the station earth, and
 - as close as possible to the location where the unconnected test object phases are connected to the station earth.
5. Connect the HV connection cable to the test object phase to test.
Observe the relevant connection diagram.
6. Remove the earthing and short-circuit connection from the phase to be tested: at the connection point and at the far end.
7. Make sure that the unconnected phases are earthed and shorted.
8. If needed, connect the external emergency off unit.
Further information: Chapter *Connecting the external emergency off unit* (on page 24)
If you are not using an external emergency off unit, ensure that the jumper plug is inserted in the  port for the external emergency off unit.
9. Connect the laptop to the *Laptop* port of the PHG 80 portable. Use the supplied Ethernet cable for this.
10. Connect the system to the supply voltage.
Further information: Chapter *Connecting the system to the supply voltage* (on page 24)

5.5.1 Cable with 3 screened phases

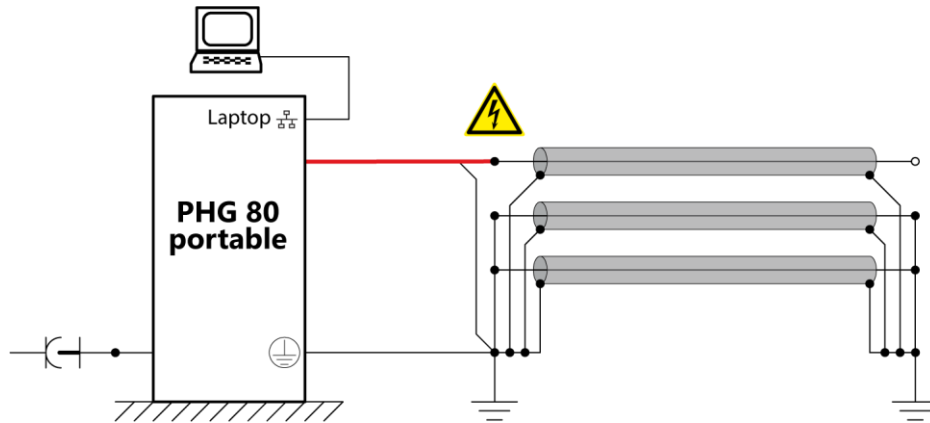

5.5.2 Cable with 1 screened phase

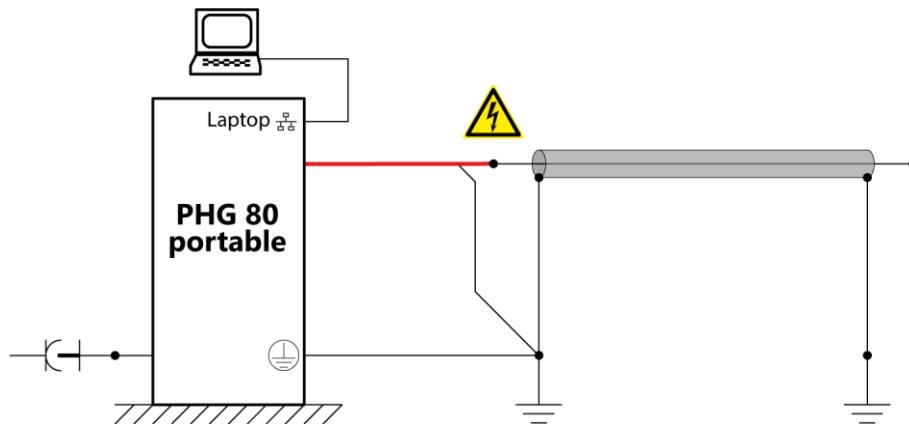

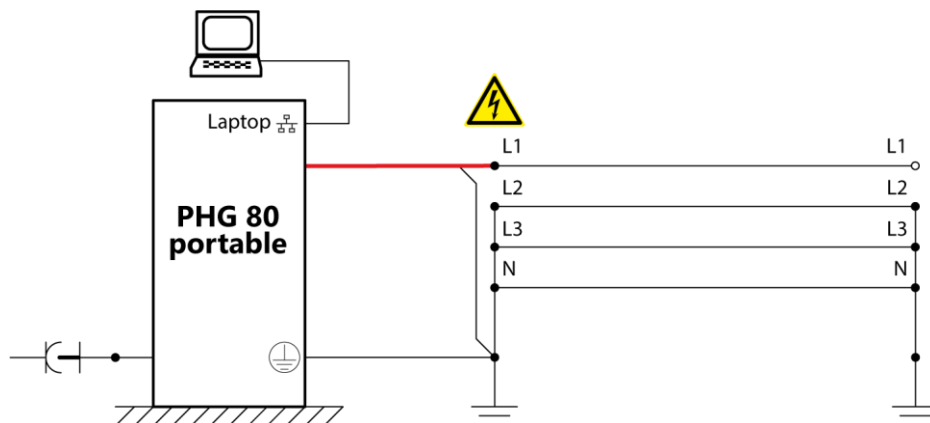

5.5.3 Unscreened cable with 3 phases

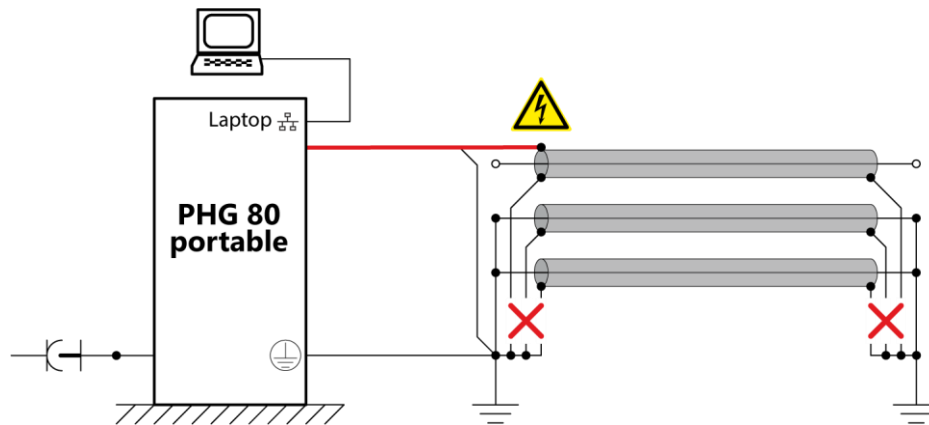

5.6 Connecting the system for cable sheath testing

The illustration shows an example of a connection diagram with a 3-phase test object. Connecting the system to a 1-phase system is similar.



1. Make sure that the connection point and the far end are prepared for the measurement tasks.
Further information: Chapter *Establishing a de-energised state* (on page 18)
2. Earth the system.
Further information: Chapter *Connecting the system to the earthing* (on page 20)
3. Make sure that the screens of all phases of the test object are disconnected from the station earth at both ends: at the connection point and at the far end.
4. Unwind the HV connection cable fully.
5. The HV connection cable screen is used for the operational earthing. Connect the screen of the HV connection cable to the station earth. Select the location for connecting the screen to the station earth as follows:
 - as close as possible to the location where the test object screens are connected to the station earth, and
 - as close as possible to the location where the unconnected test object phases are connected to the station earth.
6. Connect the HV connection cable to the test object screen.
7. Make sure that the unconnected phases are earthed and shorted.
8. If needed, connect the external emergency off unit.
Further information: Chapter *Connecting the external emergency off unit* (on page 24)
If you are not using an external emergency off unit, ensure that the jumper plug is inserted in the  port for the external emergency off unit.
9. Connect the laptop to the *Laptop* port of the PHG 80 portable. Use the supplied Ethernet cable for this.
10. Connect the system to the supply voltage.
Further information: Chapter *Connecting the system to the supply voltage* (on page 24)

5.7 Connecting the system for diagnostic measurements

The following diagnostic measurements are possible in combination with the PD-TaD portable PD diagnostics system:

- Dissipation factor measurement
- Partial discharge testing
- Parallel dissipation factor and partial discharge measurement (TD || PD measurement)
- Monitored Withstand Test with dissipation factor measurement (MWT with tan delta)
- Full Monitored Withstand Test (Full MWT)



Information on connecting, commissioning and operating the PD-TaD portable PD diagnostics system is provided in its user manual.

5.8 Connecting the external emergency off unit

The  port for the external emergency off unit is located on the connection panel on the back of the VLF test system.

1. Remove the jumper plug.
2. Connect the cable of the external emergency off unit to the  port.
3. Place the external emergency off unit outside the test area so that it is easy to reach.

5.9 Connecting the system to the supply voltage

1. Earth the system.
Further information: Chapter *Connecting the system to the earthing* (on page 20)
2. Make sure that the mains supply earth is not isolated from the station earth.
3. Make sure that the mains voltage matches the specifications on the rating plate.
4. Connect the system to the mains voltage. If necessary, use a country-specific adapter with sufficient current carrying capacity.

5.10 Securing the test area

1. Mark out the path for pedestrians.
2. Secure the connection cables, e.g. with cable bridges or rubber mats. The connection cables must be protected against damage and there must be no danger of people tripping.
3. If the connection of the device obstructs test personnel and pedestrians, these obstructions must be clearly marked.
4. Check that no-one is located in the vicinity of the test assembly (test area).
5. The test area must be demarcated from workplaces and traffic in such a way that
 - *except for the tester, no other person can remain in the test area,*
 - *except for the tester, no other person can access the prohibition zone,*
 - *persons standing outside the boundary cannot reach the operating elements of the test installations located inside the boundary. (EN 50191)*

The minimum height of individual boundaries must be 1 m or correspond to the local safety regulations and standards.

6. If the device is cordoned off from generally accessible areas only with ropes, chains or bars, the entire test assembly must be monitored during the test in compliance with EN 50191. If the test assembly includes several local test areas, security guards must be appointed for each test area. But it is important that the testing personnel and the security guards understand each other well.
7. Make sure that unauthorised persons cannot access the device and test area.
8. Mark the test area and terminals clearly. It should be immediately apparent that cable testing or measurement tasks are being performed on the cable system.
9. Make sure that unauthorised persons cannot access the connection point and the far end of the test object.
10. Make sure that the workplace is de-energised, and that the connection point and the far end of the test object are prepared for the measurement tasks.

Further information: Chapter *Establishing a de-energised state* (on page 18)

6 COMMISSIONING THE SYSTEM

- ▶ Observe the safety instructions in chapter *For your safety* (on page 8).

Procedure

1. Make sure that the system is connected properly.
Further information: Chapter *Connecting the system* (on page 18)
2. Switch on the system via the On/Off switch on the safety control unit.
 - The system status changes to the *Ready for operation* operating state.
 - The system's green indicator light lights up.
3. Switch on the laptop.
4. Start the BAUR Software 4.
 - The Dashboard opens.
 - After starting the BAUR Software, the system status is continuously monitored. The information and error messages are displayed at the top right of the screen - in the notifications bar.



Information on the messages can be found in the user manual for the BAUR Software.

7 CABLE TESTING

7.1 About cable testing

During the cable testing, a voltage is applied between phase and screen for a specific period to test the insulation. The test is considered successful if no breakdown occurs. The test duration and the voltage are defined by applicable standards based on the insulating material. The following voltage shapes are available depending on the system configuration: DC voltage, VLF truesinus® and VLF square wave voltage.

Note: Cable testing with DC voltage is not suitable for plastic-insulated cables (e.g. XLPE- or PE-insulated cables). This is due to the following reasons:

- Space charges can occur in the insulation when DC voltage is applied. When the test object is put into operation again following cable testing and AC voltage is applied, it is often at these exact points that faults occur.
- Conversely, weak points in the insulation may not be brought to the point of breakdown by DC voltage and are therefore not detected. In this case, cable testing results in a pass, even though the insulation is damaged.

For plastic-insulated cables, we recommend a test with the VLF truesinus® voltage.

Available types of cable testing

The following types of cable testing are available to you:

- Simplified cable testing with software support: Cable testing is performed using the VLF HV generator and is controlled via the BAUR Software without diagnostics function (*CABLE FAULT LOCATION* software module). Various settings are available, and the test results are displayed in the software and can be added to the report. However, it is not possible to perform a programme with different voltage steps.
Further information: Chapter *Performing simplified cable testing* (on page 27)
- Extended cable testing: Cable testing is performed using the VLF HV generator and is controlled via the BAUR Software with diagnostics function (*TESTING AND DIAGNOSTICS* software module). You can create a programme with voltage steps that are automatically tested. The test results are displayed in the software and can be saved as a report.
Further information: Chapter *Performing extended cable testing* (on page 29)

7.2 Performing simplified cable testing

Required equipment



- ▶ During measurement, always wear ear protection to protect your hearing from loud banging noises.

On the system

1. Secure the test area and connect the test object properly.
Further information: Chapter *Connecting the system* (on page 18)
2. Switch on the system and start the BAUR Software.
Further information: Chapter *Commissioning the system* (on page 25)
3. Release the high voltage on the safety control unit. To do this, press the  button.
The system status changes to the *Ready to switch on* operating state. The red indicator light comes on.

In the BAUR Software

CABLE FAULT LOCATION > Pre-location > Cable testing

1. In the phase selector, click on the phase to test.

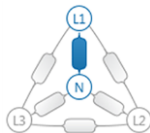

2. If you want to change the settings for the test, click on the  symbol.
Recommendation: If known, set the nominal voltage (U_n/U) of the phase to be tested. If no nominal voltage is defined, the maximum test voltage is limited by the BAUR Software.
Further information: User manual for the BAUR Software (press the *F1* key)
3. Click the **Start measurement** button.
4. If required, change the target voltage in the **Measurement** dialog.
5. In the **Measurement** dialog, click the **Start measurement** button.
The system status changes to the *In operation* operating state.
The voltage curve is displayed in the test diagram. The measurement is completed automatically:
 - after a breakdown or
 - after the set voltage holding time
6. Observe the actual current displayed during measurement. If the actual current is too high, the target voltage cannot be reached.
The cable test is considered successful if the target voltage has been reached and no breakdown has occurred within the preset time.
7. To close the **Measurement** dialog, click the **Close** button.



Information on the adjustable measurement parameters can be found in the user manual for the BAUR Software.

Next steps

- If you do not wish to perform further measurements or if you want to connect another phase: *Deactivating high voltage release* (on page 36)
- Inserting a test diagram into the report: *Inserting a test diagram into the report* (on page 28)
- Creating a report: *Creating a report in the CABLE FAULT LOCATION software module* (on page 35)

7.2.1 Inserting a test diagram into the report

1. If you want to insert the test diagram in the report, click the ***Insert graph in report*** button.

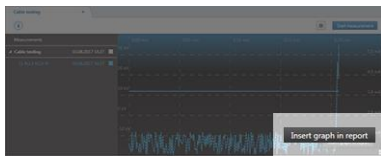

2. Enter a name for the graph and click the **OK** button.

7.2.2 Evaluating test results

Breakdown takes place

There is a cable fault. We recommend performing a cable fault location.

No breakdown achieved

- ▶ For extensive evaluation, observe the voltage and current values.

Case	Cause and further procedure
Target voltage reached	There is no fault in the tested phase. We recommend a VLF cable test in compliance with the applicable standards if this has not yet been performed.
Target voltage not reached	If the target voltage was not reached, the leakage current is too high. We recommend performing a cable fault location.

Further information: Chapter *Tips and tricks for the evaluation of measurements* (on page 34)

7.3 Performing extended cable testing

Required equipment



- ▶ During measurement, always wear ear protection to protect your hearing from loud banging noises.

On the system

1. Secure the test area and connect the test object properly.
Further information: Chapter *Connecting the system* (on page 18)
2. Switch on the system and start the BAUR Software.
Further information: Chapter *Commissioning the system* (on page 25)
3. Release the high voltage on the safety control unit. To do this, press the  button.
The system status changes to the *Ready to switch on* operating state. The red indicator light comes on.

In the BAUR Software

1. Select a cable route (*File* > **Select cable route** or *DASHBOARD* > **CABLE ROUTES** area).
2. Select **TESTING AND DIAGNOSTICS** > **Measurement**.
3. In the phase selector, click on the phase to test.
4. Select the desired sequence and click on **Cable testing** in the sequence overview.
5. Click the **Start measurement** button.

The system status changes to the *In operation* operating state.

The measurement will be performed according to the saved programme. During the measurement, the current measured values are displayed and you can see which voltage step is currently being tested (green cursor) at any time.

As soon as the measurement result is available for the first voltage step, the automatic evaluation for the entire sequence is displayed. As each voltage step is completed, the display is updated with each additional measurement within this sequence, whereby the poorest result prevails. Further information: User manual for the BAUR Software (press the *F1* key)

The test automatically finishes as soon as the defined test duration has elapsed.

You can cancel the test at any time by clicking the **Stop** button. When the test is completed or if it is cancelled, the system will automatically switch to the *Ready to switch on* operating state.



Information on the adjustable measurement parameters can be found in the user manual for the BAUR Software.

Next steps

- If you do not wish to perform further measurements or if you want to connect another phase: *Deactivating high voltage release* (on page 36)
- Creating a report: *Creating a report in the TESTING AND DIAGNOSTICS software module* (on page 35)

8 CABLE SHEATH TESTING

8.1 About cable sheath testing

The cable sheath testing is used to look for outer cable damage (sheath faults) and is recommended for new systems, after repairs and for periodic checks.

While checking for mechanical faults, a DC voltage is applied between cable sheath and earth. This testing determines whether the leakage currents that occur are within permissible limits or whether they deviate significantly from standard values due to a sheath fault.



Information on the test voltages for cable sheath testing can be found in the current versions of the following standards:

- IEC 60229
 - IEC 60502
 - DIN VDE 0276-620/621 (CENELEC HD 620/621)
-

Available types of cable sheath testing

The following types of cable sheath testing are available to you:

- Simplified cable sheath testing with software support: Cable sheath testing is performed using the VLF HV generator and is controlled via the BAUR Software without diagnostics function (*CABLE FAULT LOCATION* software module). Various settings are available, and the test results are displayed in the software and can be added to the report. However, it is not possible to perform a programme with different voltage steps.
Further information: Chapter *Performing simplified cable sheath testing* (on page 31)
- Extended cable sheath testing: Cable sheath testing is performed using the VLF HV generator and is controlled via the BAUR Software with diagnostics function (*TESTING AND DIAGNOSTICS* software module). You can create a programme with voltage steps that are automatically tested. The test results are displayed in the software and can be saved as a report.
Further information: Chapter *Performing extended cable sheath testing* (on page 33)

8.2 Performing simplified cable sheath testing

Required equipment



- ▶ During measurement, always wear ear protection to protect your hearing from loud banging noises.

On the system

1. Secure the test area and connect the test object properly.
Further information: Chapter *Connecting the system* (on page 18)
2. Switch on the system and start the BAUR Software.
Further information: Chapter *Commissioning the system* (on page 25)
3. Release the high voltage on the safety control unit. To do this, press the  button.
The system status changes to the *Ready to switch on* operating state. The red indicator light comes on.

In the BAUR Software

CABLE FAULT LOCATION > Pre-location > Cable sheath testing

1. In the phase selector select the phase that is connected to the test object screen.

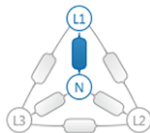

2. If you want to change the settings for the test, click on the  symbol.
Recommendation: If known, set the nominal voltage (U_0/U) of the phase to be tested. If no nominal voltage is defined, the maximum test voltage is limited by the BAUR Software.
Further information: User manual for the BAUR Software (press the *F1* key)
3. Click the **Start measurement** button.
The displayed settings are taken from the voltage assistant (**Tools > Voltage assistant**). You require administrator rights to change these settings.
Further information: User manual for the BAUR Software (press the *F1* key)
4. If required, change the target voltage in the **Measurement** dialog.
5. In the **Measurement** dialog, click the **Start measurement** button.
The system status changes to the *In operation* operating state.
The voltage curve is displayed in the test diagram. The measurement is completed automatically:
 - after a breakdown or
 - after the set voltage holding time
6. Observe the actual current displayed during measurement.
Cable sheath testing is considered successful if the test voltage is reached and remains constant, no breakdown takes place, and the leakage current does not exceed a defined value. This defined value depends on the sheath material, cable length and number of joints.
When the test is completed or if it is cancelled, the system will automatically switch to the *Ready to switch on* operating state.
7. To close the **Measurement** dialog, click the **Close** button.



Information on the adjustable measurement parameters can be found in the user manual for the BAUR Software.

Next steps

- If you do not wish to perform further measurements or if you want to connect another phase: *Deactivating high voltage release* (on page 36)
- Evaluating test results: *Evaluating test results* (on page 32)
- Creating a report: *Creating a report in the CABLE FAULT LOCATION software module* (on page 35)

8.2.1 Inserting a test diagram into the report

1. If you want to insert the test diagram in the report, click the ***Insert graph in report*** button.



2. Enter a name for the graph and click the **OK** button.

8.2.2 Evaluating test results

Breakdown takes place

There is a cable sheath fault.

If possible, pre-locate the cable sheath fault. Additional fault location equipment is required for sheath fault location, e.g. a burn down transformer and a bridge measuring unit. Proceed as follows:

1. Condition the cable sheath fault. Follow the instructions of the user manual for the respective burn down transformer.
2. Carry out the Glaser measuring bridge measurement. Follow the instructions of the user manual of the respective bridge measuring unit.
3. If the measuring bridge measurement did not produce any results, next, perform the Murray measuring bridge measurement.

Note: In the HV network, consider the network structure and cross bonding (crossing of screens). If you are working on very long cables, it is recommended feeding the voltage from the cable end close to the fault.

4. If pre-location with measuring bridge measurement is not possible, locate the cable sheath fault with a pin-pointing method.

No breakdown

- ▶ For extensive evaluation, observe the voltage and current values.

Cable sheath testing is considered successful if the test voltage is reached and remains constant, no breakdown takes place, and the leakage current does not exceed a defined value. This defined value depends on the sheath material, cable length and number of joints.

If increased leakage current was measured, there is a cable sheath fault.

Further information: Chapter *Tips and tricks for the evaluation of measurements* (on page 34)

8.3 Performing extended cable sheath testing

Required equipment



- ▶ During measurement, always wear ear protection to protect your hearing from loud banging noises.

On the system

1. Secure the test area and connect the test object properly.
Further information: Chapter *Connecting the system* (on page 18)
2. Switch on the system and start the BAUR Software.
Further information: Chapter *Commissioning the system* (on page 25)
3. Release the high voltage on the safety control unit. To do this, press the  button.
The system status changes to the *Ready to switch on* operating state. The red indicator light comes on.



In the BAUR Software

1. Select a cable route (**File** > **Select cable route** or **DASHBOARD** > **CABLE ROUTES** area).
2. Select **TESTING AND DIAGNOSTICS** > **Measurement**.
3. In the phase selector, click on the phase to test.
4. Select the desired sequence and click on **Cable sheath testing** in the sequence overview.
5. Click the **Start measurement** button.

The system status changes to the *In operation* operating state.

The measurement will be performed according to the saved programme. During the measurement, the current measured values are displayed and you can see which voltage step is currently being tested (green cursor) at any time.

If evaluation criteria are selected, the automatic evaluation for the entire sequence is displayed as soon as the measurement result is available for the first voltage step. As each voltage step is completed, the display is updated with each additional measurement within this sequence, with the poorest result prevailing. Further information: User manual for the BAUR Software (press the *F1* key)

If no evaluation criteria have been selected, you also need to observe the current and voltage curves ( view). In this view, you can create a graph and insert it in the report ( button) at any time.

The test automatically finishes as soon as the defined test duration has elapsed.

You can cancel the test at any time by clicking the **Stop** button. When the test is completed or if it is cancelled, the system will automatically switch to the *Ready to switch on* operating state.



Information on the adjustable measurement parameters can be found in the user manual for the BAUR Software.

Next steps

- If you do not wish to perform further measurements or if you want to connect another phase: *Deactivating high voltage release* (on page 36)
- Creating a report: *Creating a report in the TESTING AND DIAGNOSTICS software module* (on page 35)

9 DIAGNOSTIC MEASUREMENTS

The following diagnostic measurements are possible in combination with the PD-TaD portable PD diagnostics system:

- Dissipation factor measurement
- Partial discharge testing
- Parallel dissipation factor and partial discharge measurement (TD || PD measurement)
- Monitored Withstand Test with dissipation factor measurement (MWT with tan delta)
- Full Monitored Withstand Test (Full MWT)



Information on connecting, commissioning and operating the PD-TaD portable PD diagnostics system is provided in its user manual.

10 TIPS AND TRICKS FOR THE EVALUATION OF MEASUREMENTS

- To enable easier evaluation of a measurement, the full screen view is available. In the full screen view, the test diagram and the cable image are displayed on the full screen; the other areas are hidden.
- For detailed documentation of the measurement, you can:
 - insert a graph for a measurement in a report and
 - insert a comment regarding a measurement in the report.



Information on full screen view, graphs, and commenting in reports can be found in the user manual for the BAUR Software.

11 REPORT PREPARATION

11.1 Creating a report in the CABLE FAULT LOCATION software module

You can create a report immediately after completing cable or cable sheath testing, or do so later.

1. If not yet selected: Select a cable route (**File** > **Select cable route** or **DASHBOARD** > **CABLE ROUTES** area).
2. Select **CABLE FAULT LOCATION** > **Report**.

You can customise the report header, show and hide graphs of measurements, and record additional information.

You can save the report in the software and export it as a PDF. You can also load earlier reports.



Further information is provided in the user manual for the BAUR Software (press *F1* key).

11.2 Creating a report in the TESTING AND DIAGNOSTICS software module

1. If not yet selected: Select a cable route (**File** > **Select cable route** or **DASHBOARD** > **CABLE ROUTES** area).
2. Select **TESTING AND DIAGNOSTICS** > **Report**.

You can adjust the layout of the report, show and hide measurement data, and record additional information.

You can view earlier reports and export reports as PDFs or print them directly from the software.



Further information is provided in the user manual for the BAUR Software (press *F1* key).

12 DECOMMISSIONING THE SYSTEM

12.1 Deactivating high voltage release

1. If you do not wish to perform further measurements or if you want to connect another phase, deactivate the high voltage release on the safety control unit: To do this, press the  button.



The system's green indicator light lights up.



Dangerous voltage on the test object and other live machine parts. Danger to life, risk of injury from high electric voltage.

2. Before touching test object, discharge, earth and short-circuit the same: at the connection point and at the far end.
You may touch the plant parts that were under voltage only if they are visibly earthed and short-circuited.
3. To protect the system against restarting, press the emergency off button and remove the safety key.

12.2 Taking the system and the test area out of operation

	 DANGER
	<p>Electric voltage</p> <p>Electric shock on touching live and active parts and due to residual charges if earthing is removed too early</p> <ul style="list-style-type: none"> ▶ Disconnect the earth connections as the last connection of the test assembly. ▶ Never disconnect the earth connections as long as power and other periphery connections are still connected.

1. Deactivate the high voltage release on the safety control unit. To do this, press the  button.

The system's green indicator light lights up.



Dangerous voltage on the test object and other live machine parts. Danger to life, risk of injury from high electric voltage.

2. Before touching test object, discharge, earth and short-circuit the same: at the connection point and at the far end.
You may touch the plant parts that were under voltage only if they are visibly earthed and short-circuited.
3. Switch off the system via the On/Off switch on the safety control unit.

4. To protect the system against restarting, press the emergency off button and remove the safety key.
5. Exit the BAUR Software by clicking on the **Exit** menu item in the **File** menu.
6. Shut down the laptop.
7. To disconnect the system completely from the supply voltage, pull out the mains plug.
8. Disconnect the connection cables in the reverse order.
Important: Finally, disconnect the earth cable last.
9. Clean the connection cables.
10. Wind up the connection cables or clear them away.
11. If necessary, remove the cordoning.
12. Remove the earthing and the short-circuit on the test object only if no subsequent work is required and if the test object is to be put back into operation by the responsible individuals.
13. Remove the barriers and marking of the test area.

12.3 Exiting the measurement with the emergency off button during emergencies

1. Press the emergency off button on the safety control unit.
 - The HV generator is switched off.
 - The system's green indicator light lights up.
 - No measurement can be performed as long as the emergency off button is pressed.

 **DANGER**

Electric voltage. Electric shock on touching live and active parts and due to residual charges, danger of arcing faults.

The voltage indicator ceases to display a voltage once the emergency off button has been operated, but dangerous voltage may still be present at the test object.

2. Before touching the test object, discharge, earth and short it: at the connection point and at the far end.

You may touch the parts that were under voltage only if they are visibly earthed and short-circuited.

Further information: Chapter *Using the BAUR discharge and earth rod* (on page 39)

External emergency off unit

If an external emergency off unit is connected, you can bring the system to a safe operating state at any time using the emergency off button on the emergency off unit.

1. Press the emergency off button on the external emergency off unit.
 - The HV generator is switched off.
 - The system's green indicator light lights up.
 - No measurement can be performed as long as the emergency off button is pressed.

 **DANGER**

Electric voltage. Electric shock on touching live and active parts and due to residual charges, danger of arcing faults.

The voltage indicator ceases to display a voltage once the emergency off button has been operated, but dangerous voltage may still be present at the test object.

2. Before touching the test object, discharge, earth and short it: at the connection point and at the far end.

You may touch the parts that were under voltage only if they are visibly earthed and short-circuited.

Further information: Chapter *Using the BAUR discharge and earth rod* (on page 39)

13 USING THE BAUR DISCHARGE AND EARTH ROD

After a measurement is finished, dangerous voltage may still be present on the test object, which can lead to life-threatening injuries caused by electric shock or an arcing fault.

- ▶ Before touching the test object, discharge, earth and short it: at the connection point and at the far end.
- ▶ You may touch the plant parts that were under voltage only if they are visibly earthed and short-circuited.
- ▶ Use suitable personal protective equipment against electric shocks and arcing faults.

Procedure with the BAUR discharge and earth rod

The procedure with the BAUR earth rod is the same.

1. If not yet connected, connect the protective earthing cable of the discharge and earth rod to the station earth.
2. Assemble the discharge and earth rod: Screw the hook onto the discharge part and the discharge part onto the handle.

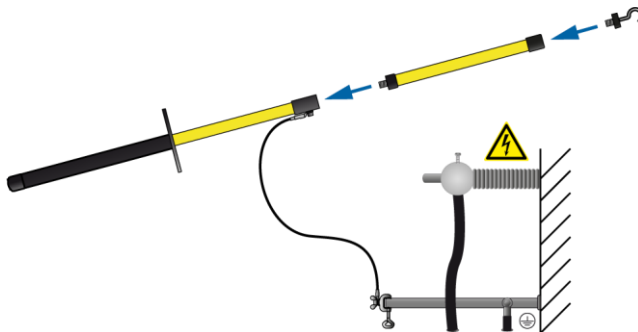

3. Only use the discharge and earth rod if its surface is clean and dry. If necessary, clean and dry the surface of the discharge and earth rod.
4. Only ever use the black handle to hold the discharge or earth rod and make contact with the test object by touching it with the hook of the discharge and earth rod.

Important:

- ▶ Keep a distance of at least 50 cm from the protective earthing cable of the discharge and earth rod.
- ▶ Observe the minimum discharge period in accordance with the capacitance of the test object.

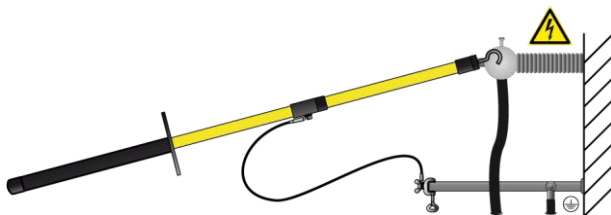

14 ERRORS AND CORRECTIVE MEASURES

NOTICE

Damage to the system due to improper handling

The user is liable for damages caused due to repairs.

- ▶ Never dismantle the system components. This may lead to damages. Inside the system components there are no components that could be serviced or repaired by the operator.
- ▶ Repairs must be carried out only by personnel trained and authorised by BAUR.

When an error message appears, proceed as follows:

1. Check the supply voltage, the connection cables and earth cable.
2. Check whether the system is in the required operating state.
3. Restart the system. Proceed as follows:
 - a. Deactivate the high voltage release on the safety control unit. To do this, press the  button.
 - b. Switch off the system via the On/Off switch on the safety control unit.
 - c. Disconnect the system from the supply voltage by pulling out the mains plug.
 - d. Wait >10 seconds and then connect the system to the supply voltage again.
Further information: Chapter *Connecting the system to the supply voltage* (on page 24)
 - e. Switch on the system via the On/Off switch on the safety control unit.
4. Restart the laptop.
Start the BAUR Software and check whether the error persists.
5. If the fault occurs again, write down the error text and the procedure that caused the error to occur.
6. Put the system out of operation and mark it accordingly.
7. Contact your nearest BAUR representative.



Further information on the error messages can be found in the user manual for the BAUR Software.

15 MAINTENANCE AND CARE

NOTICE

Damage to the system due to improper handling

The user is liable for any damage caused due to improper maintenance or care.

- ▶ Never take apart the system and installed components. This can damage the device. There are no components in the system or other integrated components that can be serviced or repaired by the operator.
- ▶ Maintenance tasks must be carried out only by personnel trained and authorised by BAUR.

15.1 Maintenance intervals

Component	Interval	Maintenance work
General maintenance tasks	Before each use	Check the system and connection cables for physical damage
	After each use	Clean the system and connection cables and check for physical damage
Laptop	As required	Clean the display

15.2 Cleaning the system

NOTICE

Damage to the device may be caused by using the wrong cleaning agents

- ▶ Do not use any abrasive, corrosive cleaning agents or strong solvents.
- ▶ Ensure material compatibility.
- ▶ Do not clean the product with acetone or thinner.
- ▶ Never clean electrical devices with water.

Required equipment

- Mild detergent
- Lint-free cleaning cloth

Procedure

1. Before carrying out any maintenance or cleaning work, switch off the system and disconnect it from the supply voltage.
Further information: Chapter *Taking the system and the test area out of operation* (on page 36)
2. If required, clean the device surfaces with mild detergent and a lint-free cloth.
NOTICE! Device damage due to leaking fluids.
3. Do not allow liquids to leak into the devices.

15.3 Checking and cleaning the connection cables and connection accessories

NOTICE**Damage to cable due to aggressive cleaning agents**

- ▶ Do not use any abrasive, corrosive cleaning agents or strong solvents.
- ▶ Ensure material compatibility.
- ▶ Do not clean the connection cables with acetone or thinner.

Required equipment

- Mild detergent
- Lint-free cleaning cloth

Checking and cleaning after each use

1. Before carrying out any maintenance or cleaning work, switch off the system and disconnect it from the supply voltage.
Further information: Chapter *Taking the system and the test area out of operation* (on page 36)
2. Each time after using the system, clean all the connection cables used and wind them up or clear them away.
3. Check the connection cables for damage.
Cracks, breaks or other damage in the connection cable can damage the cable.
4. If dirty, clean the connection accessories with a lint-free cloth.
Dirty or corroded contacts can affect the measurement and are often the cause for device damage.

Regular inspection

- ▶ Before and after each time you use the system, check the condition of all the connection cables. If necessary, to do this, unwind the connection cables fully and check them for cracks, damage and dirt.
- ▶ Regularly check all connection accessories for damage and dirt.

16 TRANSPORTATION AND STORAGE

NOTICE**Damage to the system due to incorrect transportation and improper storage**

- ▶ Transport and store the system so that it always remains in an upright position.
- ▶ Protect the system and its components against strong vibrations, moisture and unauthorised access.
- ▶ Comply with the ambient conditions specified in the technical data.

Further information: Chapter *Data sheet* (on page 48)

17 WARRANTY AND AFTER SALES

Warranty

For warranty claims, please contact BAUR GmbH or your local BAUR representative. Improper use will render the warranty null and void. Wear parts are excluded from the warranty.

After Sales

For questions contact BAUR GmbH or your BAUR representative.



BAUR GmbH

Raiffeisenstr. 8
6832 Sulz / Austria
service@baur.eu
<https://www.baur.eu>

18 DISPOSAL

The final decommissioning and disposal of the system must be carried out only in compliance with country-specific laws, regulations and standards.

System components do not belong in the domestic waste.

- ▶ Dispose of electrical system components in accordance with the applicable national regulations.
- ▶ Dispose of the various system components in an environmentally friendly manner and in accordance with the applicable national regulations.

19 DECLARATION OF CONFORMITY

We

BAUR GmbH
Raiffeisenstr. 8
6832 Sulz
Austria

declare, under our sole responsibility, that the product

VLf test system
PHG 80 portable

to which this declaration refers, conforms to the following standards or standard documents:

- Low Voltage Directive 2014/35/EC
EN 61010-1:2010
EN 61010-2-030:2010
EN 50191:2010
- EMC Directive 2014/30/EU
EN 55011:2009 + A1:2010
EN 61000-4-2:2009
EN 61000-4-4:2004 + A1:2010
- Environmental testing
EN 60068-2-ff

Signed: Dr. Markus Baur, CEO

Sulz, dd.mm.2024

20 INDEX

A

About cable sheath testing • 30

About cable testing • 26

About this manual • 6

Applicable documents • 6

Avoiding dangers, taking safety measures • 9

C

Cable sheath testing • 30

Cable testing • 26

Cable with 1 screened phase • 22

Cable with 3 screened phases • 22

Checking and cleaning the connection cables and connection accessories • 42

Checking and maintaining the safety devices and accessories • 10

Cleaning the system • 41

Commissioning the system • 25

Connecting the external emergency off unit • 24

Connecting the system • 18

Connecting the system for cable sheath testing • 23

Connecting the system for cable testing • 21

Connecting the system for diagnostic measurements • 24

Connecting the system to the earthing • 20

Connecting the system to the supply voltage • 24

Creating a report in the CABLE FAULT LOCATION software module • 35

Creating a report in the TESTING AND DIAGNOSTICS software module • 35

D

Dangers when working with electric voltage • 10

Data sheet • 48

Deactivating high voltage release • 36

Declaration of conformity • 45

Decommissioning the system • 36

Diagnostic measurements • 34

Disposal • 44

E

Errors and corrective measures • 40

Establishing a de-energised state • 18

Evaluating test results • 28, 32

Exiting the measurement with the emergency off button during emergencies • 37

F

For your safety • 8

Front view • 12

Full illustration • 12

I

Inserting a test diagram into the report • 28, 32

Intended use • 8

M

Maintenance and care • 41

Maintenance intervals • 41

N

No operation during condensation • 10

No operation in areas with risk of explosion and fire • 10

No unauthorised modifications to the system • 9

Note on the screenshots and graphics used • 7

O

Operating states • 17

Operation by qualified personnel • 8

Operation only in a technical secure state • 9

P

Performing extended cable sheath testing • 33

Performing extended cable testing • 29

Performing simplified cable sheath testing • 31

Performing simplified cable testing • 27

PHG 80 VLF HV generator • 13

Ports on the back • 13

Product information • 11

R

Rating plate of the PHG VLF HV generator • 16

Rating plate of the system • 15

Rating plates • 15

Report preparation • 35

S

Safety instructions • 19

SCU safety control unit • 14

Securing the test area • 24

Setting up the system • 18

Special personal protective equipment • 11

Structure of safety instructions • 6

System checks to perform before commissioning • 17

System connection cables • 15

T

Taking the system and the test area out of operation • 36

Tips and tricks for the evaluation of measurements • 34

Transportation and storage • 43

U

Unscreened cable with 3 phases • 22

Using the BAUR discharge and earth rod • 39

V

View settings • 7

W

Warranty and After Sales • 43

PHG 80 portable BAUR VLF test system



The figure is illustrative.

true: sinus®

Portable, high performance test generator with VLF truesinus® technology

- 3 voltage shapes in one device
- For medium-voltage cables of up to 50 kV operating voltage
- Convenient to operate with simple user guidance

The PHG 80 portable VLF test system is used for cable and cable sheath testing of medium-voltage cables up to 50 kV and offers three tried-and-tested voltage shapes:

VLF truesinus® and VLF square wave voltage

BAUR VLF truesinus® digital technology enables the most reliable detection of damage and offers the comparability of measurement results by means of load-independent voltage generation with digital control. Unlike other voltage shapes, the voltage is exact, symmetrical and continuous. The cable length has no influence on the test level. Medium-voltage cables are tested with utmost care and in compliance with the standards.

DC voltage

For DC voltage testing, e.g. for paper-insulated mass-impregnated cables, the PHG 80 VLF HV generator provides a stabilised DC voltage with positive and negative polarity of up to 80 kV.

The PHG 80 portable satisfies the highest requirements with regard to safety, robustness, operational convenience and automation.

Functions

- Max. test voltage up to 57 kV_{rms}
- Cable testing according to:
IEC 60502, DIN VDE 0276-620/621
(CENELEC HD 620/621), IEC 60060-3,
IEEE 400.2-2013, IEEE 400-2012
- Cable sheath testing according to IEC 60229

Features

- High-performance test generator with 3 kW
 - Compact, in a 19" housing
 - Control via laptop
 - Load-independent, reproducible sinusoidal high voltage by means of VLF truesinus® testing technology
 - Adjustable test frequency: 0.01 Hz – 0,1 Hz
 - Automatic sequences and reporting
 - Use of standardised diagnostics sequences for different applications and cable routes that can be accessed simply on site
 - Automatic breakdown detection
 - Burn mode or safe shutdown on breakdown
 - Intuitive user interface in multiple languages adapted to the work flow
 - Safety control unit in compliance with EN 50191
 - Variable connection options to cable stations of different models
 - Can be expanded in combination with the PD-TaD 62 or PD-TaD 80 to include:
 - Dissipation factor and partial discharge measurements
 - Monitored Withstand Test with dissipation factor measurement (TD-MWT)
 - Full Monitored Withstand Test (Full MWT)
- Further details on the individual methods can be found in the BAUR Software 4 cable testing and diagnostics data sheet

Technical data

Output voltage	
Frequency range	0.01 – 0,1 Hz
VLF truesinus®	<ul style="list-style-type: none"> ▪ 1 - 57 kV_{rms} ▪ 1.4 – 80.6 kV_{peak}
VLF square wave voltage	1 – 80 kV
DC voltage (positive / negative)	1 – 80 kV
Max. capacitive load	<ul style="list-style-type: none"> ▪ Up to 20 µF ▪ 1.2 µF @ 0.1 Hz @ 57 kV_{rms} ▪ 3 µF @ 0.1 Hz @ 38 kV_{rms} ▪ 4 µF @ 0.1 Hz @ 30 kV_{rms}
Resolution	0.1 kV
Accuracy	1%
Output current	
Output current	<ul style="list-style-type: none"> ▪ 1.8 mA @ 80 kV ▪ 60 mA @ 50 kV ▪ 90 mA @ 20 kV
Max. burn current	120 mA
Resolution	10 µA
Accuracy	1%
Dissipation factor measurement*	
VLF truesinus®	1 – 57 kV _{rms}
Load range	≥10 nF
Measurement range	0.1 x 10 ⁻³ – 1,000 x 10 ⁻³
Accuracy	1 x 10 ⁻⁴
Resolution	1 x 10 ⁻⁶ (mean value of the dissipation factor)
Detection and compensation of leakage currents	Automatic

* In combination with the PD-TaD 62 or PD-TaD 80

BAUR Software 4

Details about the BAUR Software 4 and the system requirements can be found in the data sheet for the BAUR Software 4.

General

Power supply	220 – 240 V, 50/60 Hz
Option	100 – 120 V, 50/60 Hz (with external auto transformer)
Max. power consumption	3,500 VA
Reverse voltage protected	Up to 16 kV
Degree of protection	IP22
Dimensions VLF HV generator (W x H x D)	Approx. 755 x 850 x 991 mm (19", 15 RU)
Weight VLF HV generator	Approx. 199 kg, incl. rack and connection cable
Ambient temperature (VLF HV generator)	-20°C to +55°C (from 45°C with reduction in performance)
Storage temperature (VLF HV generator)	-30°C to +70°C
Relative humidity	Non-condensing
Safety and EMC	CE-compliant in accordance with Low Voltage Directive (2014/35/EU), EMC Directive (2014/30/EU), EN 60068-2-ff Environmental testing

Standard delivery

PHG 80 portable VLF test system:

- PHG 80 VLF HV generator
- SCU safety control unit
- Laptop incl.
 - pre-installed BAUR software 4
 - pre-installed Windows operating system
 - carrying bag
- GDR 80-500 discharge and earth rod
- Ethernet cable, 3 m
- 19" rack for PHG 80 portable incl. HV connection cable, earth cable and mains supply cord, cable lengths of 10 m respectively
- Set of 4 wheels for 19" rack, mounted
- Carry handle, 2 pcs
- User manual

Accessories and options

- External auto transformer, 110/230 V; 3.0 kVA
- BAUR Software 4 for office PC (office installation)

Optional software functions

- Mapping (available countries on request)
- GIS interface



Would you like to discover more about this product?
If so, contact us: www.baur.eu > BAUR worldwide



BAUR GmbH

Raiffeisenstr. 8
6832 Sulz / Austria
T +43 (0)5522 4941-0
F +43 (0)5522 4941-3
headoffice@baur.eu
<https://www.baur.eu>